

# Surface Mount Power Splitter/Combiner

4 Way-0° 50Ω 5 to 1000 MHz

**JS4PS-1W+**  
**JS4PS-1W**

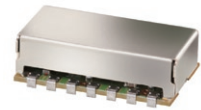

## Maximum Ratings

Operating Temperature	-40°C to 85°C
Storage Temperature	-55°C to 100°C
Power Input (as a splitter)	0.5W max.
Internal Dissipation	0.375W max.

## Pin Connections

SUM PORT	10
PORT 1	2
PORT 2	3
PORT 3	5
PORT 4	6
GROUND	1,4,7,8,9,11,12,13,14

## Outline Drawing

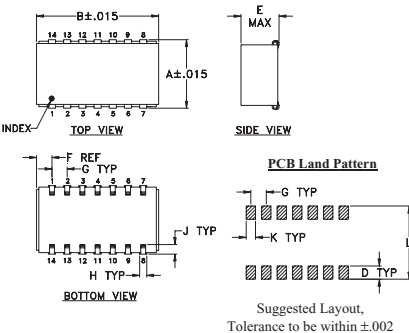

## Outline Dimensions (inch/mm)

A	B	C	D	E	F
.505	.800	--	.100	.250	.100
12.83	20.32	--	2.54	6.35	2.54
G	H	J	K	L	wt
.100	.047	.065	.065	.525	grams
2.54	1.19	1.651	1.65	13.34	3.0

## Demo Board MCL P/N: TB-133 Suggested PCB Layout (PL-091)

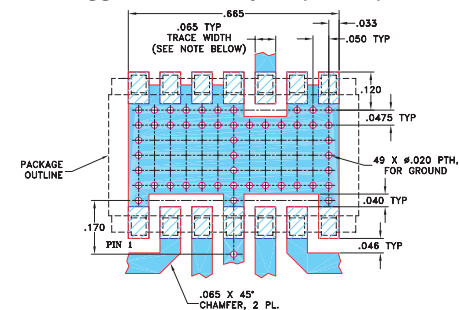

NOTE: TRACE WIDTH IS SHOWN FOR FR4 WITH DIELECTRIC THICKNESS 0.030" ± .002". COPPER: 1/2 OZ. EACH SIDE. FOR OTHER MATERIALS TRACE WIDTH MAY NEED TO BE MODIFIED.

- DENOTES PCB COPPER LAYOUT
- DENOTES COPPER LAND PATTERN FREE OF SOLDER MASK

## Features

- wideband frequency, 5 to 1000 MHz
- good input matching, VSWR 1.2 typ.
- good output matching, VSWR 1.1 typ.
- shielded case
- aqueous washable
- protected under US patent 6,963,255

## Applications

- VHF/UHF-TV receivers/transmitters
- cellular

## Electrical Specifications

FREQ. RANGE (MHz)	ISOLATION (dB)			INSERTION LOSS (dB) ABOVE 6.0 dB			PHASE UNBALANCE (Degrees)			AMPLITUDE UNBALANCE (dB)								
	L		M	U		L		M	U		L		M	U				
	Typ.	Min.	Typ. Min.	Typ. Min.	Typ. Max.	Typ. Max.	Typ. Max.	Max.	Max.	Max.	Max.	Max.	Max.	Max.				
$f_L$ - $f_U$																		
5-1000	29	20	26	18	20	15	0.3	1.1	0.8	1.5	1.5	2.4	5	5	12	0.8	0.7	0.7

L = low range [ $f_L$  to 10  $f_L$ ] M = mid range [10  $f_L$  to  $f_U/2$ ] U = upper range [ $f_U/2$  to  $f_U$ ]

## Typical Performance Data

Freq. (MHz)	Insertion Loss (dB)				Amp. Unbal. (dB)	Isolation (dB)			Phase Unbal. (deg.)	VSWR S	VSWR 1	VSWR 2	VSWR 3	VSWR 4
	S-1	S-2	S-3	S-4		1-2	2-3	3-4						
5.00	6.56	6.36	6.41	6.21	0.36	30.36	37.82	29.37	0.69	1.05	1.35	1.29	1.32	1.26
10.00	6.53	6.34	6.39	6.20	0.34	32.42	39.54	31.18	0.39	1.04	1.31	1.25	1.28	1.23
30.00	6.57	6.38	6.42	6.24	0.33	32.75	39.14	31.56	0.18	1.05	1.29	1.24	1.26	1.21
50.00	6.59	6.40	6.44	6.26	0.33	31.59	38.16	30.74	0.23	1.06	1.28	1.23	1.25	1.21
70.00	6.61	6.42	6.46	6.28	0.33	30.35	37.24	29.84	0.28	1.07	1.28	1.23	1.25	1.21
100.00	6.64	6.44	6.49	6.30	0.34	28.75	36.00	28.60	0.48	1.09	1.27	1.22	1.25	1.20
200.00	6.73	6.54	6.59	6.40	0.33	25.05	32.97	25.41	0.99	1.14	1.25	1.20	1.23	1.19
300.00	6.80	6.62	6.66	6.48	0.32	23.04	31.34	23.48	1.43	1.16	1.22	1.18	1.21	1.17
400.00	6.88	6.70	6.74	6.56	0.32	22.03	30.78	22.32	1.93	1.15	1.20	1.17	1.21	1.16
500.00	6.94	6.77	6.83	6.64	0.31	21.60	30.97	21.54	2.25	1.13	1.17	1.16	1.18	1.15
600.00	7.03	6.88	6.91	6.74	0.29	21.44	31.71	20.88	2.64	1.09	1.15	1.16	1.16	1.15
700.00	7.12	6.99	7.02	6.85	0.26	21.20	32.66	20.14	2.87	1.07	1.14	1.17	1.15	1.16
800.00	7.23	7.13	7.16	7.00	0.24	20.60	32.77	19.28	3.13	1.12	1.13	1.18	1.14	1.16
900.00	7.39	7.33	7.33	7.19	0.20	19.68	31.58	18.40	3.28	1.18	1.12	1.19	1.13	1.16
1000.00	7.56	7.56	7.51	7.39	0.17	18.66	29.87	17.60	3.43	1.24	1.10	1.19	1.10	1.15

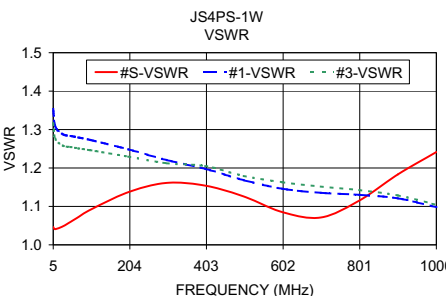
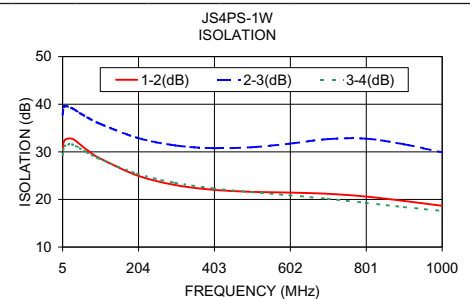
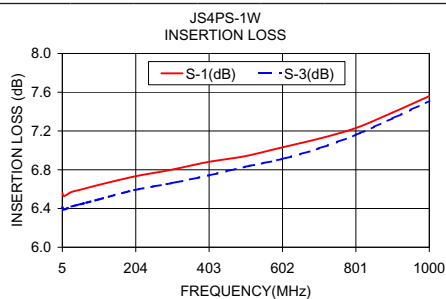

## electrical schematic



**Mini-Circuits®**  
ISO 9001 ISO 14001 AS9100 CERTIFIED

**minicircuits.com**

P.O. Box 350166, Brooklyn, New York 11235-0003 (718) 934-4500 Fax (718) 332-4661 For detailed performance specs & shopping online see Mini-Circuits web site



The Design Engineers Search Engine Provides ACTUAL Data Instantly From MINI-CIRCUITS At: [www.minicircuits.com](http://www.minicircuits.com)

RF/IF MICROWAVE COMPONENTS

REV. C  
M98898  
ED-8390/2  
JS4PS-1W  
WZ/TD/CP/AM  
081028