

Surface Mount

Power Splitter/Combiner

GP2Y1+

2 Way-0° 50Ω 1550 to 4400 MHz

Maximum Ratings

Operating Temperature	-40°C to 85°C
Storage Temperature	-65°C to 150°C
Power Input (as a splitter)	1.5W max.
Internal Dissipation	0.75W max.

Pad Connections

SUM PORT	2
PORT 1	7
PORT 2	9
GROUND	1,3,4,5,6,8,10,11,12, paddle

Product Marking

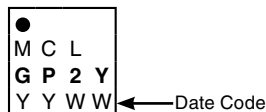

Outline Drawing

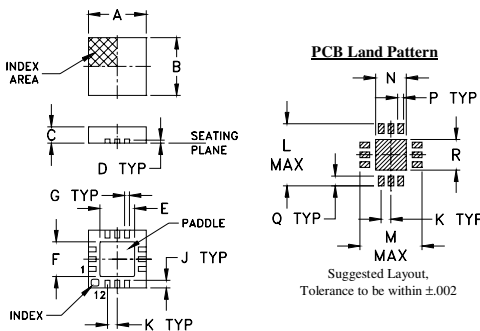

Outline Dimensions (inch/mm)

A	B	C	D	E	F	G	H	J
.118	.118	.035	.008	.057	.057	.009	---	.016
3.00	3.00	0.89	0.20	1.45	1.45	0.23	---	0.41
K	L	M	N	P	Q	R		wt
.020	.127	.127	.049	.010	.020	.049		grams
0.51	3.23	3.23	1.24	0.25	0.51	1.24		0.02

Demo Board MCL P/N: TB-453-GP2Y1+ Suggested PCB Layout (PL-282)

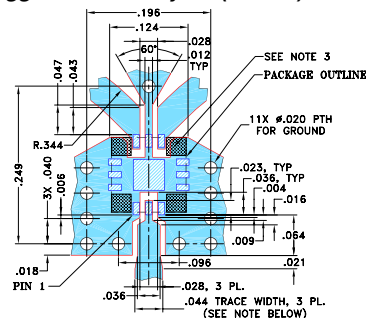

NOTES:

- TRACE WIDTH IS SHOWN FOR ROGERS RO4350B WITH DIELECTRIC THICKNESS .020" ± .0015"; COPPER: 1/2 OZ. EACH SIDE. FOR OTHER MATERIALS TRACE WIDTH AND GAP MAY NEED TO BE MODIFIED.
- BOTTOM SIDE OF THE PCB IS CONTINUOUS GROUND PLANE.
- SIGNAL TRACES ARE NOT ALLOWED INSIDE HATCHED AREAS (APPROX. .030 X .030) AT 4 PLACES AS SHOWN.

- DENOTES PCB COPPER LAYOUT WITH SMOBC (SOLDER MASK OVER BARE COPPER)
- DENOTES COPPER LAND PATTERN FREE OF SOLDER MASK

Features

- wide bandwidth, 1550 to 4400 MHz
- excellent isolation, 20 dB typ.
- excellent amplitude unbalance, 0.04 dB typ.
- good phase unbalance, 0.6 deg. typ.
- small size, 0.118"x0.118"x0.035"
- high ESD level
- aqueous washable

Applications

- WCDMA
- radar
- instrumentation
- WiMax
- DCS
- navigation
- Korea PCS

Electrical Specifications

FREQ. RANGE (MHz)	ISOLATION (dB)		INSERTION LOSS* (dB) ABOVE 3.0 dB		PHASE UNBALANCE (Degrees)	AMPLITUDE UNBALANCE (dB)	VSWR (:1) Typ.	
	Typ.	Min.	Typ.	Max.	Max.	Max.	Port S	Ports 1,2
1550-4400	20	12	1.0	1.9	6.0	0.3	1.4	1.4

* De-embedded from demo board loss.

Typical Performance Data

Frequency (MHz)	Insertion Loss (dB)		Amplitude Unbalance (dB)	Isolation (dB)	Phase Unbalance (deg.)	VSWR S	VSWR 1	VSWR 2
	S-1	S-2						
1470.00	4.45	4.44	0.01	16.20	0.33	1.73	1.30	1.31
1690.00	3.84	3.83	0.01	35.04	0.41	1.07	1.15	1.15
1870.00	3.74	3.74	0.00	24.68	0.47	1.16	1.14	1.15
2140.00	3.70	3.72	0.02	21.93	0.54	1.31	1.17	1.19
2320.00	3.67	3.69	0.02	22.75	0.57	1.30	1.16	1.17
2490.00	3.64	3.66	0.02	24.97	0.59	1.23	1.12	1.15
2670.00	3.62	3.63	0.01	29.75	0.51	1.13	1.08	1.10
2940.00	3.64	3.65	0.00	33.00	0.45	1.10	1.09	1.08
3120.00	3.70	3.70	0.00	25.78	0.45	1.21	1.17	1.15
3300.00	3.77	3.78	0.01	21.67	0.49	1.36	1.24	1.24
3490.00	3.85	3.88	0.03	18.91	0.64	1.51	1.31	1.33
3680.00	3.93	3.97	0.04	17.04	0.71	1.63	1.38	1.40
3870.00	3.98	4.05	0.07	15.77	0.85	1.71	1.44	1.51
4240.00	4.07	4.12	0.05	14.38	1.01	1.77	1.66	1.71
4430.00	4.11	4.13	0.01	14.09	0.95	1.77	1.83	1.83

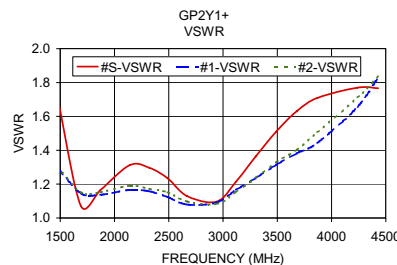
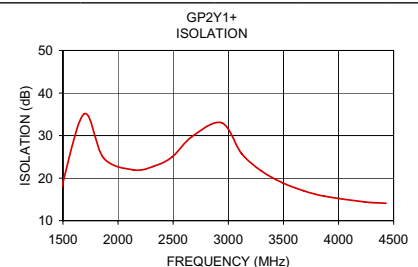
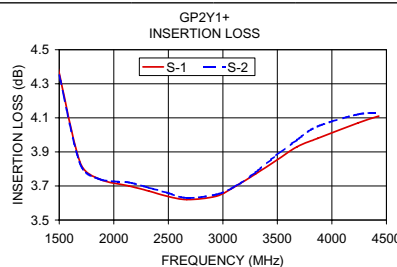

electrical schematic



ESD Rating

Human Body Model (HBM): Class 1A (250 to < 500V) in accordance with ANSI/ESD STM 5.1 - 2001
Machine Model (MM): Class M2 (100V to < 250V) in accordance with ANSI/ESD STM 5.2 - 1999

Mini-Circuits®
ISO 9001 ISO 14001 AS9100 CERTIFIED

minicircuits.com

P.O. Box 350166, Brooklyn, New York 11235-0003 (718) 934-4500 Fax (718) 332-4661 For detailed performance specs & shopping online see Mini-Circuits web site



The Design Engineers Search Engine Provides ACTUAL Data Instantly From MINI-CIRCUITS At: www.minicircuits.com

RF/IF MICROWAVE COMPONENTS

Rev. A
M119987
GP2Y1+
ED-13012A/2
RS/CP
081028